

# A255P Standard Economy Hand Dryer

## AUTOMATIC – No. HD15350

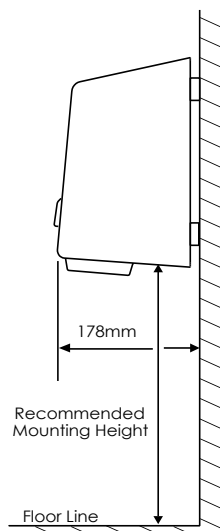
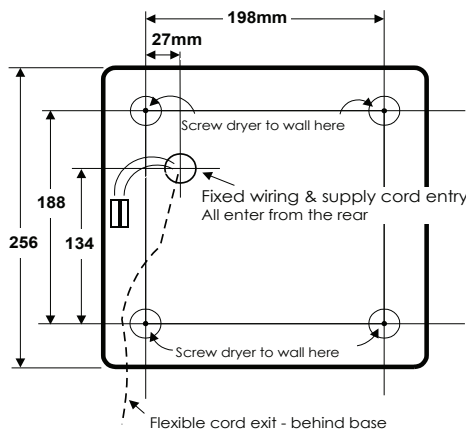

### FEATURES

Fully automatic infra-red operation. Economic, tough, all ABS construction. Fast drying cycle with high velocity blower. Long life motor and carbon brushes. Easy to clean surfaces. Hygiene and safety approved.

### SPECIFICATIONS

Construction: All plastics are flame retardant to UL94 VO, Class II double insulated, enclosure splash/drip proof to IPX2, non-corrosive. Gross weight 2.6kgs. Shipping weight 2.8kgs. Colour: white with grey trim. Electrical rating 220-240 V~ 50-60Hz, 2.40 kW, 10AMP. Noise level 69 dB. Air volume 5.4 M3/min. Air velocity 175 km/hr.

### SIZE

Height - 260 mm  
Width - 260 mm  
Depth - 180 mm

### PLANNING

Generally, one hand dryer is recommended for every two hand basins. For heavy use in large washrooms, use two hand dryers for every three basins. Automatic model A255P must be mounted with clear space underneath the dryer to prevent interference to the infra-red control which operates in that zone. Install hand dryers adjacent to wash basins, out of the way of projecting storage cabinets or other objects to optimise access and movement around the dryer.

In congested areas, site dryers to ensure good traffic flow between wash basins and dryers. If more than one is used, dryers should be placed at least 500mm to 600mm apart.

### ELECTRICAL SAFETY APPROVALS

AS3304, AS3300, NZ6362, NZ6300, IEC335-2-23:1996, IEC 335-1:1991 incl Amend 1, EN55014, EN50082-1, EN60555-2/3, International CB Text Certificate No. AU0182, Certificate of suitability No. CS/781/Q

### ELECTRICAL CONNECTION & ADDITIONAL NOTES

Installation and servicing should be carried out by a qualified person. Fixed wiring is recommended for all installations. Wiring should emerge from the wall at the position marked fixed wiring & supply cord entry. All wiring, related switches and circuit protection must be installed in accordance with local electrical wiring regulations and codes. When dryers are provided with a supply cord and plug, the plug must be located in an accessible position. This unit is double insulated and does not require earthing/grounding.

### RECOMMENDED MOUNTING HEIGHTS

From the floor to the bottom of the dryer:

Men's washrooms - 1200mm. Women's washrooms - 1150mm.  
Children's washrooms ages up to 10 - 860mm. Children's washrooms ages up to 16 - 1120mm.  
Disabled person's washrooms - 1015mm.

### TOTAL SATISFACTION WARRANTY

Factory Warranty - Limited- 10 years  
Electronic Control Only Warranty - 2 years

DISABLED PERSON COMPLIANT

EMC COMPLIANT Z184

Designed and Manufactured in New Zealand



Phone 0800 802 861 095702861  
Fax 095702864  
Email sales@ardrich.co.nz